

SEE NOTE
 ON "GEAR
 HOUSING
 CHART"
 BEFORE
 ORDERING
 FROM THIS
 PAGE

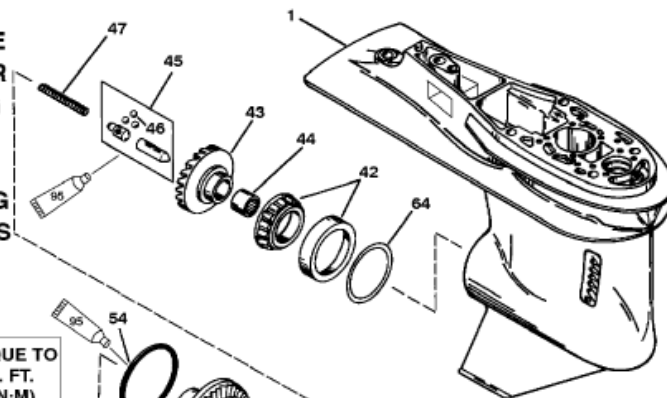

TORQUE TO
 55 LB. FT.
 (74.6 N·M)

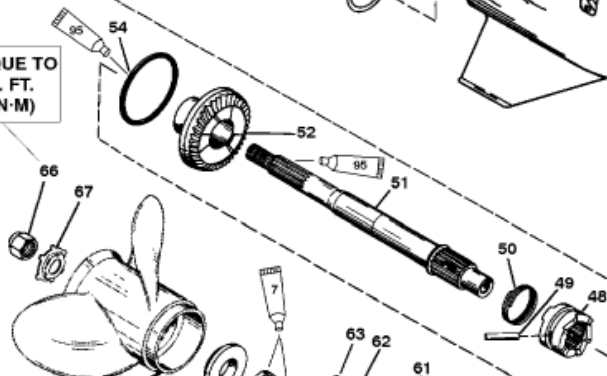

4.25 IN./107.95MM
 TORPEDO DIA.
 2.07:1/2.31:1
 GEAR RATIO

**Quicksilver Lubrication/Sealant
 Application Points**

-  2-4-C With Teflon (92-825407A12)
-  Loctite 271 (Obtain Locally)

Parts List

Ref	Class	Part	Description	Qty	Comment	Footnote
1	1667	9011A73	GEAR HOUSING	1	(BLACK)	
1	1667	9011A74	GEAR HOUSING	1	(GRAY)	
1	1667	9011A80	GEAR HOUSING	1	(TRACKER-GRAPHITE GRAY)	
42	31	30894A 1	TAPERED ROLLER BEARING AS:	1		
43		NSS	FORWARD GEAR (PART OF 43-1:	1	(2.07:1 GEAR RATIO - 29 TEETH 6	
43	43	12634A 2	FORWARD GEAR	1	(HIGH ALTITUDE) (2.31:1 GEAR	
44	31	30895	ROLLER BEARING	1		
45		12239A 1	CAM FOLLOWER ASSEMBLY	1		
46	30	44530	BALL	3		
47	24	30622	SPRING	1		
48	52	822539	CLUTCH	1		
49	17	30632	CROSS PIN	1		
50	24	30893	SPRING	1		
51	44	12238T	PROPELLER SHAFT	1		
52		NSS	REVERSE GEAR (PART OF 43-19	1	(2.07:1 GEAR RATIO - 29 TEETH 6	
52	43	12635	REVERSE GEAR	1	(HIGH ALTITUDE) (2.31:1 GEAR	
53		12596A 2	BEARING CARRIER ASSEMBLY	1		
54	25	97386	O-RING	1		1,8
55	31	30956	ROLLER BEARING	1		
56	26	76868	OIL SEAL (INNER)	1		8
57	26	70081	OIL SEAL (OUTER)	1		8
58	31	12578	ROLLER BEARING	1		
59	12	12577	THRUST WASHER	1		
60	31	12576	THRUST BEARING	1		
61	16	42917 2	STUD	2		
62	12	70132	WASHER	2		
63	11	40119 8	NUT	2		
64	15	44491A 1	SHIM ASSEMBLY	1		
65		13191A 1	THRUST HUB ASSEMBLY	1	THESE PARTS ARE NOT INCLU	
66	11	52707A 1	PROPELLER NUT ASSEMBLY	1	THESE PARTS ARE NOT INCLU	
67	14	816629	TAB WASHER	1	THESE PARTS ARE NOT INCLU	
-	26	43035A 4	G/H SEAL KIT	1		
-	27	13461A90	GASKET SET	1		